

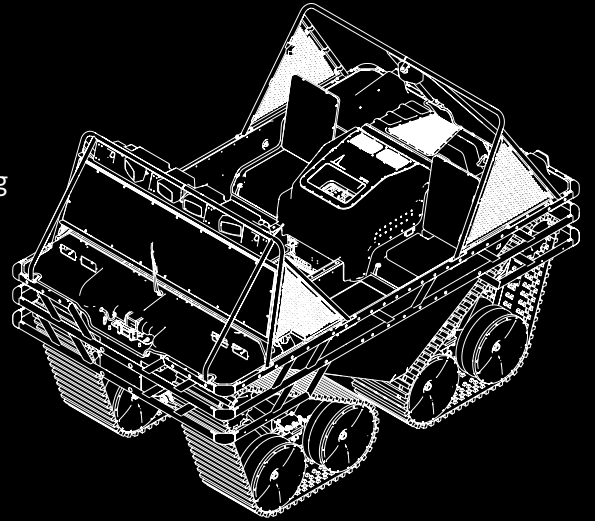

Vanquisher

Vanquisher is an all-terrain vehicle platform tailored for squadron support missions. It offers an advanced 'Follow Me' mode, enabling autonomous navigation across diverse terrains. The platform easily adapts to various tasks such as transporting light weaponry, carrying injured personnel, and operating effectively in muddy or challenging conditions.

Vanquisher's key strengths include versatile customization options and the integration of non-frictional CVTs (continuously variable transmissions), which enhance mobility and speed. These attributes improve its reliability and overall effectiveness in demanding environments.



Logistic Unmanned Ground Vehicle

The L-UGV is an excellent choice for field logistics, capable of safely handling hazardous or high-value materials. It can be used in remote control (RC) mode or first-person view (FPV), ensuring that personnel are removed from potentially risky situations during transport.

Its gravity-stabilized platform maintains balance on uneven terrains like hills or slopes, securely keeping cargo in position. By operating autonomously, it mitigates human exposure to danger and reduces the risk of accidents and material loss.

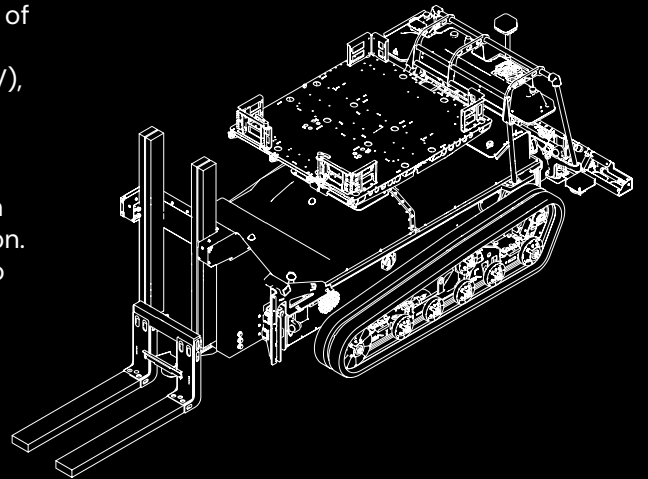

Firefighting Vehicle

This specialized firefighting robot is equipped with a foam generator, 1,700-liter water tank and a 170-liter foam concentrate tank. It effectively combats fires in remote or hard-to-reach areas — particularly useful for emergency scenarios such as ammunition, fuel depot or underground parking garage fires.

Using medium-expansion foam at ratios of 1:20 or 1:50, the firefighting vehicle can suppress large fires quickly without relying on external hoses or water sources. Its compact design allows towing by light car trailer, providing rapid deployment in critical situations.

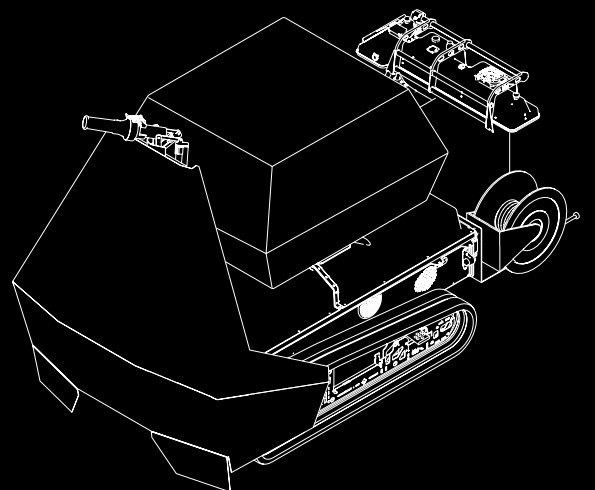

Deminer

This configuration excels in demining operations by functioning in both FPV mode and autonomous mode with RTK-level accuracy. It navigates through minefields with precise guidance, ensuring minimal risk to human operators in hazardous areas.

A standout benefit is its durable construction, offering resistance to explosive impacts. This resilience allows for the creation of lightweight mine trails that protect following units from potential threats, enhancing safety and operational efficiency.

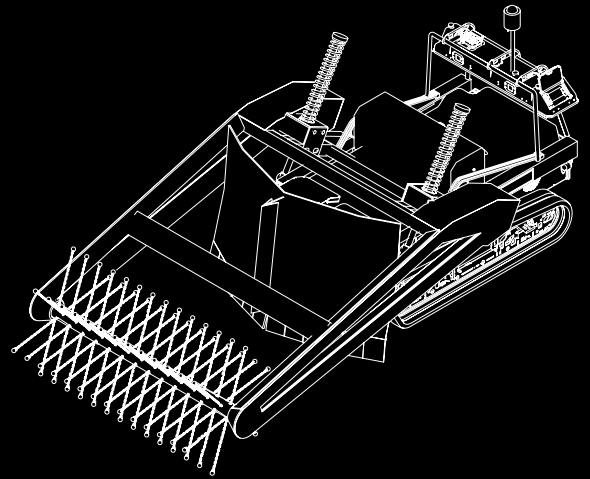

Decontamination system

A rotating duct spraying system equipped for the decontamination of radioisotope, biological, and chemical contaminants. By enabling operations through remote control, first-person view, voice control, or follow-me mode, it removes personnel from high-risk areas.

Its versatility allows for swift and thorough decontamination processes across a wide range of scenarios. The system's design minimizes human exposure to toxic materials, making it an invaluable asset for military and disaster response teams alike.

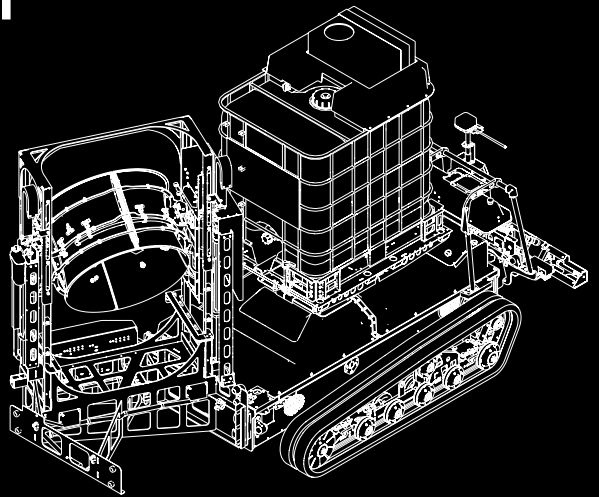

Short Range Counter UAV

The SR cUAV is an autonomous combat vehicle designed to detect, track, and neutralize diverse UAV threats. It operates autonomously or semi-autonomously, with command oversight via a tactical tablet, providing responsive and precise air defense.

Regardless of weather conditions, this caterpillar-based system can effectively locate and engage targets using its turret equipped with two automatic guns.

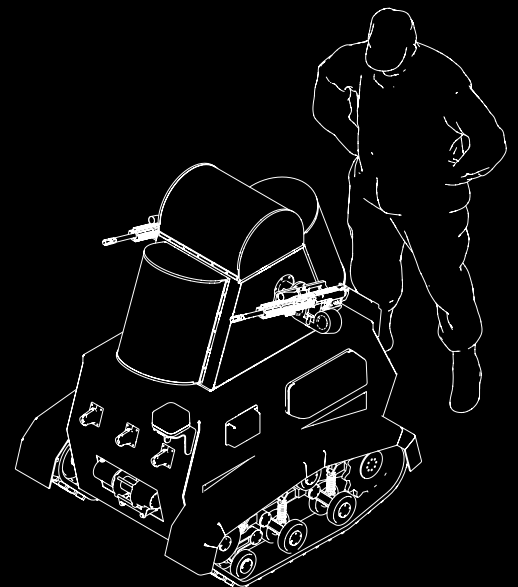

Tailored Electric Vehicle Solutions for Your Needs

At PEK Automotive d.o.o., we are leaders in crafting innovative electric vehicle solutions tailored to your unique defense project requirements. We provide you with top-tier expertise, comprehensive support, and cutting-edge technology to bring your vision to life.



Our dedicated team of diverse experts is committed to delivering exceptional results and meets all your project requirements alongside our innovative software and firmware solutions.



Our one-stop production under one roof includes mechanical and electrical workshops, advanced testing labs, and quality control to ensure seamless integration and reliability.



Every project is unique, and at PEK, we recognize this. Our solutions are 100% customized, designed to meet your exact needs with flexibility and precision.



We are dedicated to continuous improvement through feedback, leading to evolved solutions that meet current standards and surpass expectations.



Commitment to improvement and forward-thinking technology.

Why Choose PEK?

Tailored solutions that adapt to your specific requirements.

A dedicated team of professionals guiding you through every phase.

One-stop service from design to production, including software development.

PEK Automotive d.o.o. is your trusted partner for custom electric vehicle projects.

With our unique combination of expertise, advanced technology, and client-focused approach, we are here to support you from concept to completion.

Let us help you build the electric vehicle of your dreams.



PEK Automotive d.o.o.
Obrtniška Ulica 17
1370 Logatec, Slovenia
+386 30 777 050
info@pekauto.com

